

ODU AMC[®] NP

Quick disconnect circular connector

BREAK-AWAY

HIGH
CURRENT
CONTACTS



ODU AMC[®] NP

ODU AMC[®]

ODU AMC[®] EASY-CLEAN

ODU AMC[®] HIGH-DENSITY

ODU AMC[®] THREADED CONNECTOR

ODU AMC[®] SERIES T

ODU AMC[®] NP

FEATURES

- Quick disconnect
- High current contacts
- High-speed data transfer capability, including USB[®] 2.0
- Break-away for maximum safety
- Ruggedized design tested to MIL-STD-810H
- Improved power contacts
- IP68, 20 m [120 min]
- Minimum 2,000 mating cycles
- Cable assembly integrated solutions
- Compatible to all GOSSRA, NATO and Nett Warrior Standards

APPLICATIONS

- Tactical soldier batteries
- PDU (Power Distribution Units)
- CWB (Conformable Wearable Batteries)
- C4ISR peripherals



All shown connectors are according to IEC 61984:2008 (VDE 0627:2009-11) connectors without breaking capacity (COC). All shown connectors and cable assemblies are rated to a safety extra low voltage (SELV) of less than 50 V AC / 75 V DC, according to IEC 61140:2016 (VDE 0140-1:2016-11). For more details, please refer to page [46](#).

All dimensions are in mm.
Some figures are for illustrative purposes only. Subject to change without notice. Errors and omissions excepted. We reserve the right to change our products and their technical specifications at any time in the interest of technical improvement. This publication supersedes all prior publications.

This publication is also available as a PDF file that can be downloaded from odu-connectors.com

Issue: 2022-10

Data transmission protocols

The contact arrangement of an ODU data transmission connector differs from a standard data transmission connector due to the robust ODU specific design. However, the ODU design meets the electrical specifications of the respective standard data transmission protocol.

Performance may be limited in cable length due to cable specifications. Please consult factory.

TABLE OF CONTENTS

PRODUCT INFORMATION	5
ODU AMC® connectors at a glance	6
ODU circular connectors – related products	6
ODU AMC® NP locking mechanism – break-away locking	7
CONFIGURATION	9
ODU AMC® sample configuration step by step	10
Cable specifications	14
ODU AMC® NP	17
Summary ODU AMC® NP	19
Break-away plug and cable assembly	20
In-line receptacle and cable assembly	24
Panel mount receptacle and cable assembly	28
Flange mount receptacle	30
Keying options	31
Contact inserts and PCB layouts	32
ACCESSORIES	35
Protection caps	36
Custom parts	37
TOOLS	39
Banding tools	40
Contact crimp tools	40
Insertion and removal tools	40
Nutdriver for slotted nut	41
Heat shrink	41
Complete your connector system	41
TECHNICAL INFORMATION	43
Technical data – ODU AMC® NP	44
International protection classes	50
Conversions / AWG	51
International color code / IC-code	52
Technical terms	53

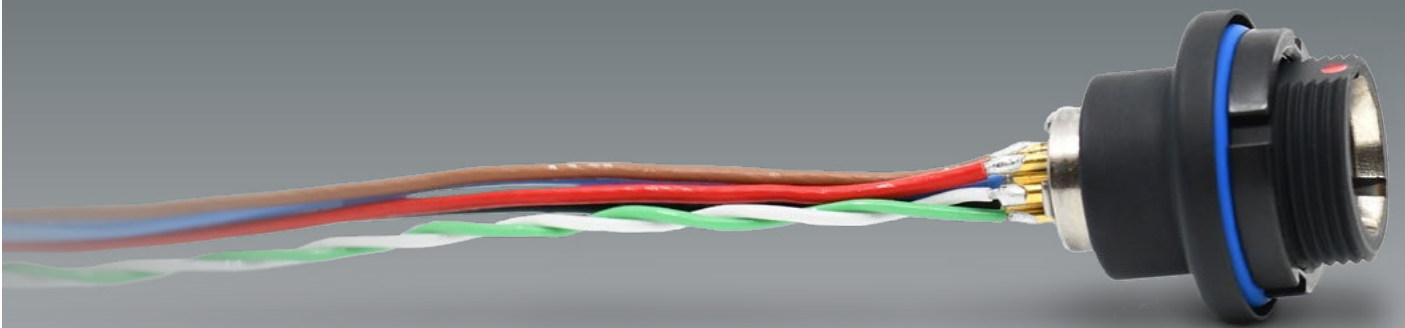

ODU AMC® NP



PRODUCT INFORMATION

ODU AMC® connectors at a glance	6
ODU circular connectors – related products	6
ODU AMC® NP locking mechanism – break-away locking	7

ODU AMC[®] CONNECTORS AT A GLANCE

The ODU AMC[®] series has been designed especially for use in standard power applications. These incredibly robust series of metal circular connectors leave absolutely nothing to be desired in terms of toughness and transmission reliability.

They are in their element under extreme field conditions: rugged, watertight and easy to clean. Low weight, low light reflection surfaces, excellent EMC properties and a compact design make these connectors the ideal choice for military and security technology applications.

These connectors are available as system solutions with cable assemblies for harsh environments and with straight or right-angled overmolding.



ODU CIRCULAR CONNECTOR SERIES RELATED PRODUCTS



- High speed data transmission versions
- Secure push-pull locking and break-away function
- Contacts for solder and PCB termination
- International protection class IP6K8 and IP6K9K
- Customized cable assemblies



- Pogo pin contacts can be easily cleaned and are resilient against damage caused by dirt and debris ingress
- Break-away function
- International protection class IP6K8 and IP6K9K
- Customized cable assemblies



- Small and compact design
- High contact density
- High speed data transmission versions
- Break-away function
- International protection class IP6K8 and IP6K9K
- With dual-locking option (screw-lock or break-away)
- Preterminated cable assemblies and customized cable assemblies.

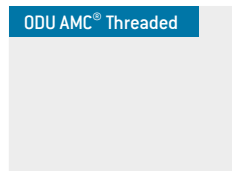

- High reliability for harsh environments
- Thread-lock with ratchet mechanism (180°)
- High vibration resistance
- Contacts for solder and PCB termination
- Up to 2,000 mating cycles
- International protection class IP6K8 and IP6K9K
- Customized cable assemblies



- Waterproof in accordance with MIL – Standard 810
- Operating temperature range from –65° C to +175° C
- Sealed mechanical components, thus completely protected
- Suitable for MIL back-shell and MIL crimp contacts
- Highly flexible solution
- Standard cable assemblies with UL rated cables and single wires

ODU AMC[®] NP LOCKING MECHANISM

BREAK-AWAY LOCKING

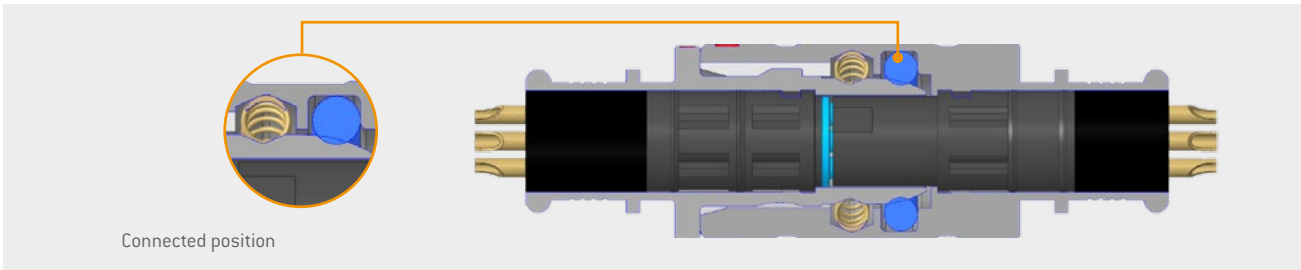

The break-away function allows connectors to be mated and unmated quickly and reliably. During the mating process, a canted spring inside the receptacle engages corresponding grooves on the plug. Once established, the connection will be maintained as long as spring tension is less than the release limit of the connector system.

The canted spring is strong enough to resist minor tension. Pulling lightly on the plug or cable assembly will have no impact on the connection.

If the plug or cable assembly is pulled forcefully, and the release limit of the connector is exceeded then the connectors will separate at 13 +/- 3 lbf [57.8 N +/- 13.3 N]. Design features within the connector allow a damage-free demating if either the plug or the cable assembly is pulled away from the receptacle with enough force to overcome the retention mechanism.



ODU AMC® NP



CONFIGURATION

ODU AMC® NP sample configuration step by step	10
Cable specifications	14

STEP-BY-STEP TO THE PERFECT CONNECTION

ODU offers high-quality connectors and comprehensive service for the complete assembly. From connectors to watertight potting, we provide the complete system from a single source.



11 different mechanical keying options and keying with color-coded identification

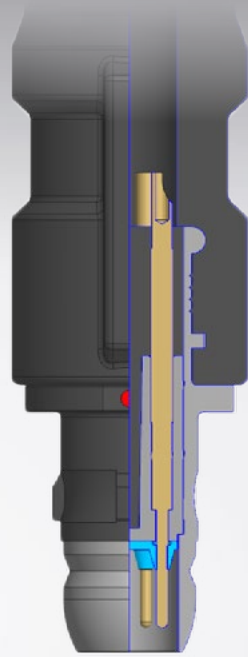

← Cable assembly (optional)

← Contacts for solder, crimp and PCB

3 termination types

2 inserts with reverse gender

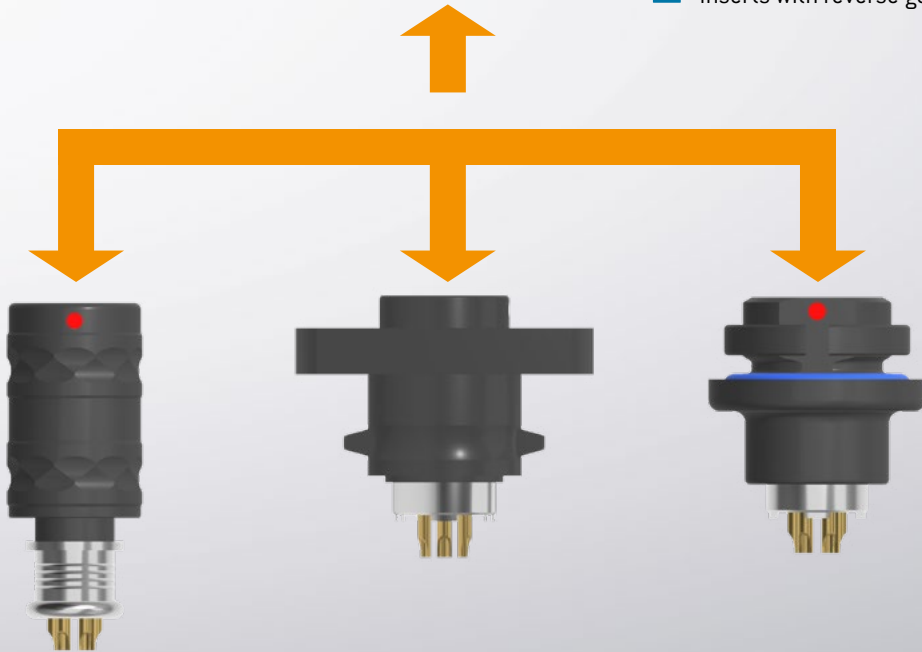

Cable assembly (optional)

IN-LINE RECEPTACLE

FLANGE

Contacts for solder or PCB termination

RECEPTACLE

SAMPLE CONFIGURATION STEP BY STEP

The perfect product for you in just a few steps. These step-by-step instructions shows how to configure your own individual product with the ODU part number key based on a sample configuration.

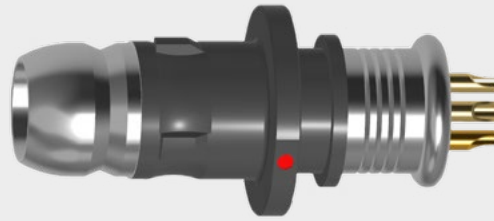

Plug style 1 / size 6 / series /Ø keyway / connector housing / insulator PEEK / 6 contacts / solder pin / termination size 23 cross section AWG 22

STEP 1: SERIES (SEE POSITION 4)

1	2	3	4	5	6	7	8	9	10	11	12	13	14	15	16	17	18	19
			N		P	-							0	-	0	0	0	

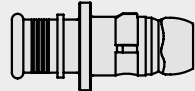
←  ODU AMC® NP

STEP 2: STYLE (SEE POSITIONS 1 AND 2)

1	2	3	4	5	6	7	8	9	10	11	12	13	14	15	16	17	18	19
A	1		N		P	-							0	-	0	0	0	0

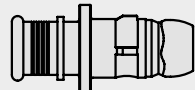
←  BREAK-AWAY PLUG

STEP 3: SIZE (SEE POSITION 3)

1	2	3	4	5	6	7	8	9	10	11	12	13	14	15	16	17	18	19
A	1	6	N		P	-							0	-	0	0	0	0

←  SIZE 6

STEP 4: KEYING (SEE POSITION 5)

1	2	3	4	5	6	7	8	9	10	11	12	13	14	15	16	17	18	19
A	1	6	N	Ø	P	-							0	-	0	0	0	0

←  KEYING Ø

STEP 5: HOUSING MATERIAL (SEE POSITION 6)

1	2	3	4	5	6	7	8	9	10	11	12	13	14	15	16	17	18	19
A	1	6	N	Ø	P	-							0	-	0	0	0	0

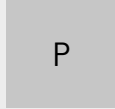
←  P

RoHS COMPLIANT BLACK CARBON FINISH

STEP 6: INSULATOR MATERIAL (SEE POSITION 8)

1	2	3	4	5	6	7	8	9	10	11	12	13	14	15	16	17	18	19
A	1	6	N	0	P	-	P						0	-	0	0	0	0



PEEK

STEP 7: INSERT ARRANGEMENT (SEE POSITIONS 9 AND 10)

1	2	3	4	5	6	7	8	9	10	11	12	13	14	15	16	17	18	19
A	1	6	N	0	P	-	P	0	6				0	-	0	0	0	0

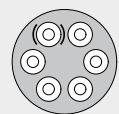

06 CONTACTS

STEP 8: CONTACT TYPE (SEE POSITION 11)

1	2	3	4	5	6	7	8	9	10	11	12	13	14	15	16	17	18	19
A	1	6	N	0	P	-	P	0	6	X			0	-	0	0	0	0

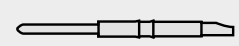

SOLDER (PIN)

STEP 9: CONTACT DIAMETER (SEE POSITION 12 AND 13)

1	2	3	4	5	6	7	8	9	10	11	12	13	14	15	16	17	18	19
A	1	6	N	0	P	-	P	0	6	X	2	3	0	-	0	0	0	0

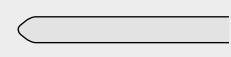

CONTACT DIAMETER

CABLE & OVERMOLDING SPECIFICATIONS

TECHNICAL DATA



SINGLE WIRE MIL-W-16878/4C

Conductor:	Silver plated copper, 22 AWG, 19 / 34
Insulation:	PTFE, Ø 1.3 mm MIL-W-16878/4C [Type E]
Specifications:	Voltage rating: 600 V (RMS), MIL-W-16878/4C [Type E] Temperature rating: -60 °C up to + 200 °C
Colors:	White, Black, Red, Green, Yellow, Blue, Brown, Orange, Slate, Violet

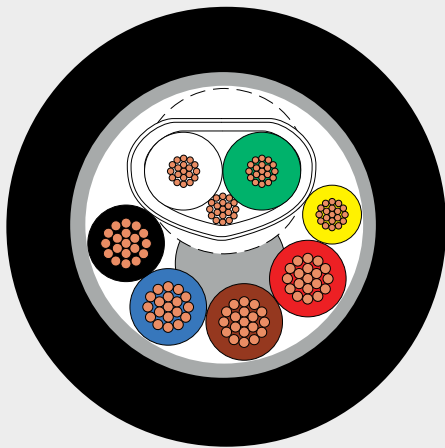

MULTI-CONDUCTOR CABLE PUR - SHIELDED TECHNICAL DATA

Conductors:	Tin copper wire, twisted pair, 26 AWG, 19 / 38 [White, Green] Tin copper wire, 1 @ 26 AWG, 19 / 38 [Yellow] Tin copper wire, 4 @ 22 AWG, 19 / 34 [Black, Blue, Brown, Red]
Outer shield:	Braided, 87 % nom. coverage
Inner shield:	Braided, 96 % nom. coverage
Jacket:	FR polyurethane, Ø 6.65 mm
Specifications:	Voltage rating: 600 V (RMS) Temperature rating: -40 °C up to + 90 °C Twisted pair: 90 Ω ± 15 %



OVERMOLDING TECHNICAL DATA

Material:	TPU
Color:	Black
Operating temperature:	-40 °C to +85 °C
Flamability:	UL 94 (HB)

CIRCULAR CONNECTORS COMPLETE WITH CABLE ASSEMBLY

ODU AMC® NP is the ideal circular connector for a wide range of applications. This metal, rugged connector enhances a soldier's ability to communicate in the battlefield and is tested to MIL-STD-810H and applicable technical requirements.

It contains improved power contacts along with USB® 2.0 capabilities, a minimum of 2,000 mating cycles and it's waterproof up to IP68 with 20 m waterproof versions available. There are options for solder, crimp, or PCB terminations, with easy handling and a robust break-away design.

ODU AMC® NP connector is ideal for tactical soldier batteries, PDU (power distribution units), CWB (conformable wearable batteries), and C4ISR peripherals for the transmission of USB® 2.0 signals and power. It's compatible with open architecture standards such as NATO STANAG 4695, Nett Warrior, and GOSSRA (General Open Structure Architecture).

This connector gives a significant competitive advantage to equipment manufacturers that want a highly reliable and readily available connectivity solution.

ODU provides complete cable assembly integrated solutions as well as rapid prototyping for custom / hybrid connectors.

CONNECTOR
MEETS
CABLE

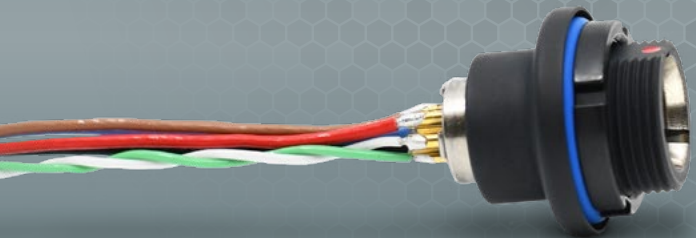

COMPLETE SYSTEM SOLUTIONS

Every connection has a unique cable requirement. Make no compromise when it comes to the quality of the complete interconnect system. ODU gives you the complete system solution from one source, without the need for an intermediary supplier.

Services include:

- + One point of contact for a complete system
- + High technical expertise in the processing of third-party products
- + 100 % final inspection
- + Custom labeling and cable printing
- + Close collaboration with leading cable manufacturers
- + Process-controlled solder and crimp monitoring from initial samples to full production
- + Inhouse Technology Test Center for the development of technologies for customer-specific requirements
- + Production according to IPC standards



ODU AMC® NP



ODU AMC[®] NP

Summary ODU AMC [®] NP	19
Break-away plug	20
In-line receptacle	24
Panel mount receptacle	28
Flange mount receptacle	30
Keying options	31
Contact configurations and PCB details	32
Protective caps	34
Custom parts	35
Assembly and crimp tools	44



ODU
ODU AMC
Advanced Military
Connectors

SUMMARY ODU AMC® NP

The ODU AMC® NP is keyed by pin and groove. These highly robust miniature connector series can be configured in many different ways: a variety of styles, termination types and contact inserts are available.

- Keying pin and groove
- 6 and 7 position
- 1 size, 3 termination types
- Environmental protection class up to IP68 20 meters, 120 minutes
- Minimum 2,000 mating cycles
- Contacts for solder, crimp and PCB termination

BREAK-AWAY PLUG

P. 20



A 1

IN-LINE RECEPTACLE

P. 24



K 1

PANEL MOUNT RECEPTACLES

P. 28

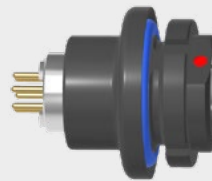

G K

FLANGE MOUNT RECEPTACLE

P. 30

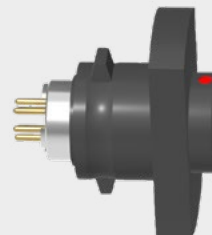

B 0

CABLE ASSEMBLY – BREAK-AWAY PLUG – SOLDER

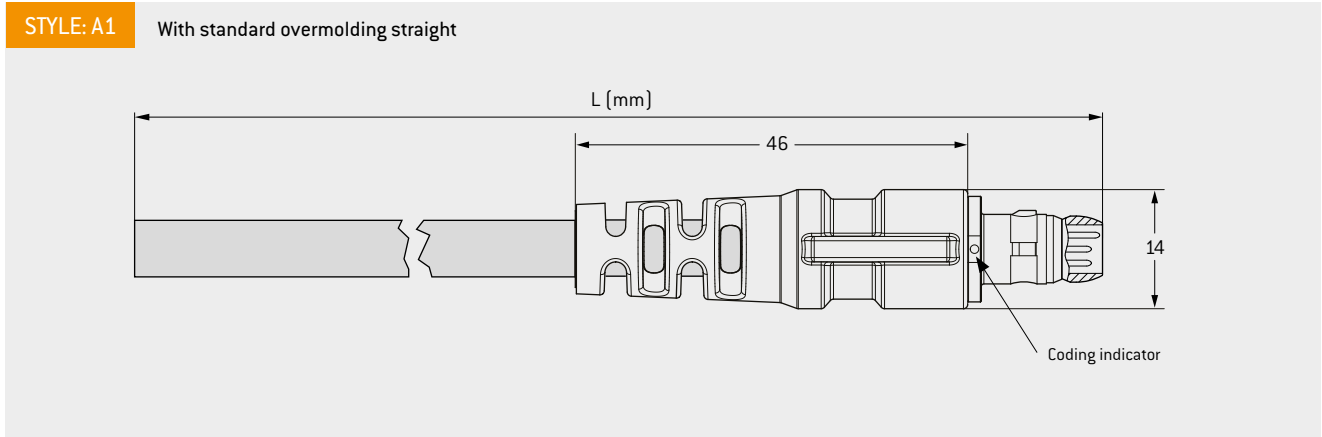

Cable assembly

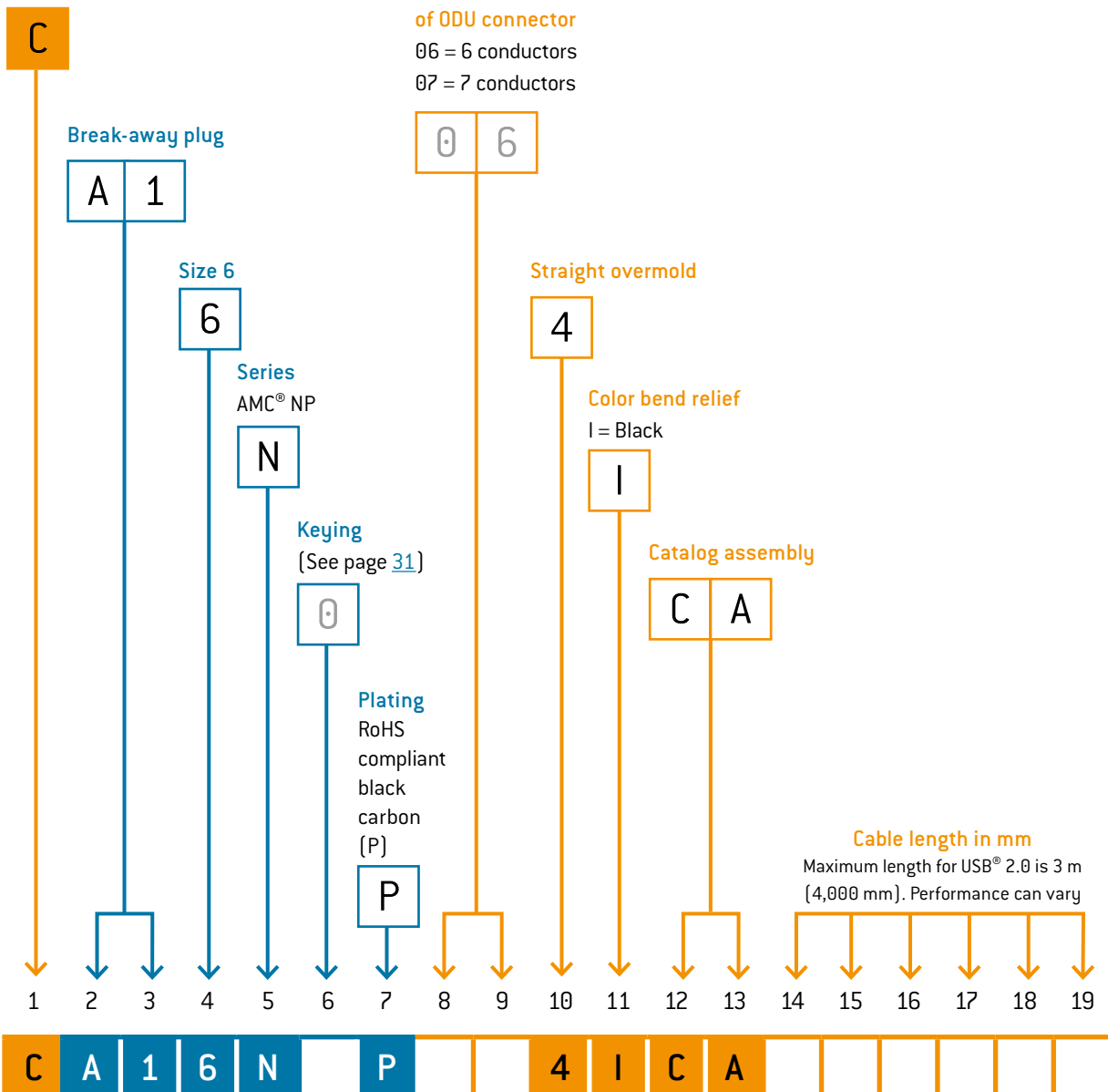

CABLE ASSEMBLY – BREAK-AWAY PLUG – SOLDER

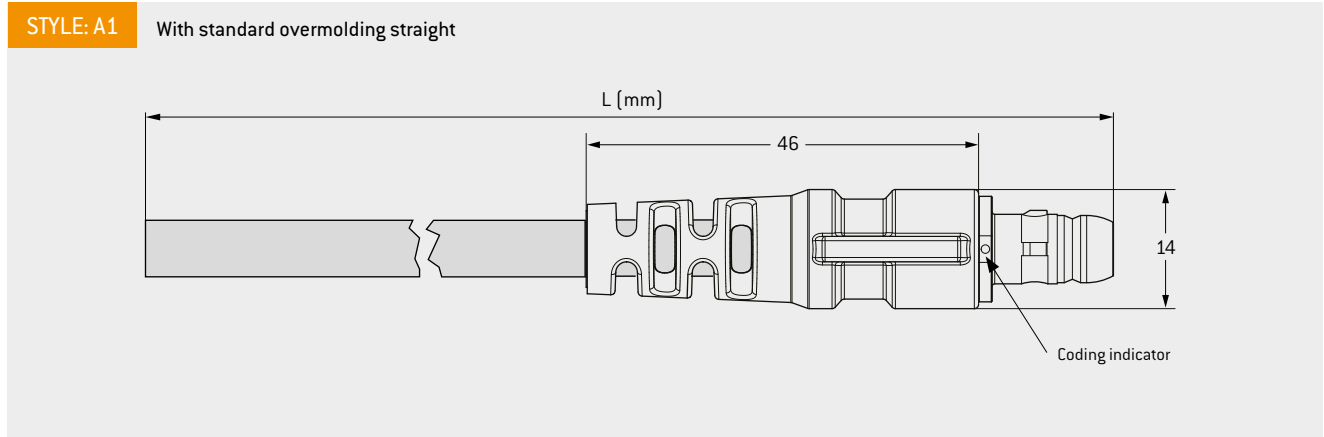

Cable assembly

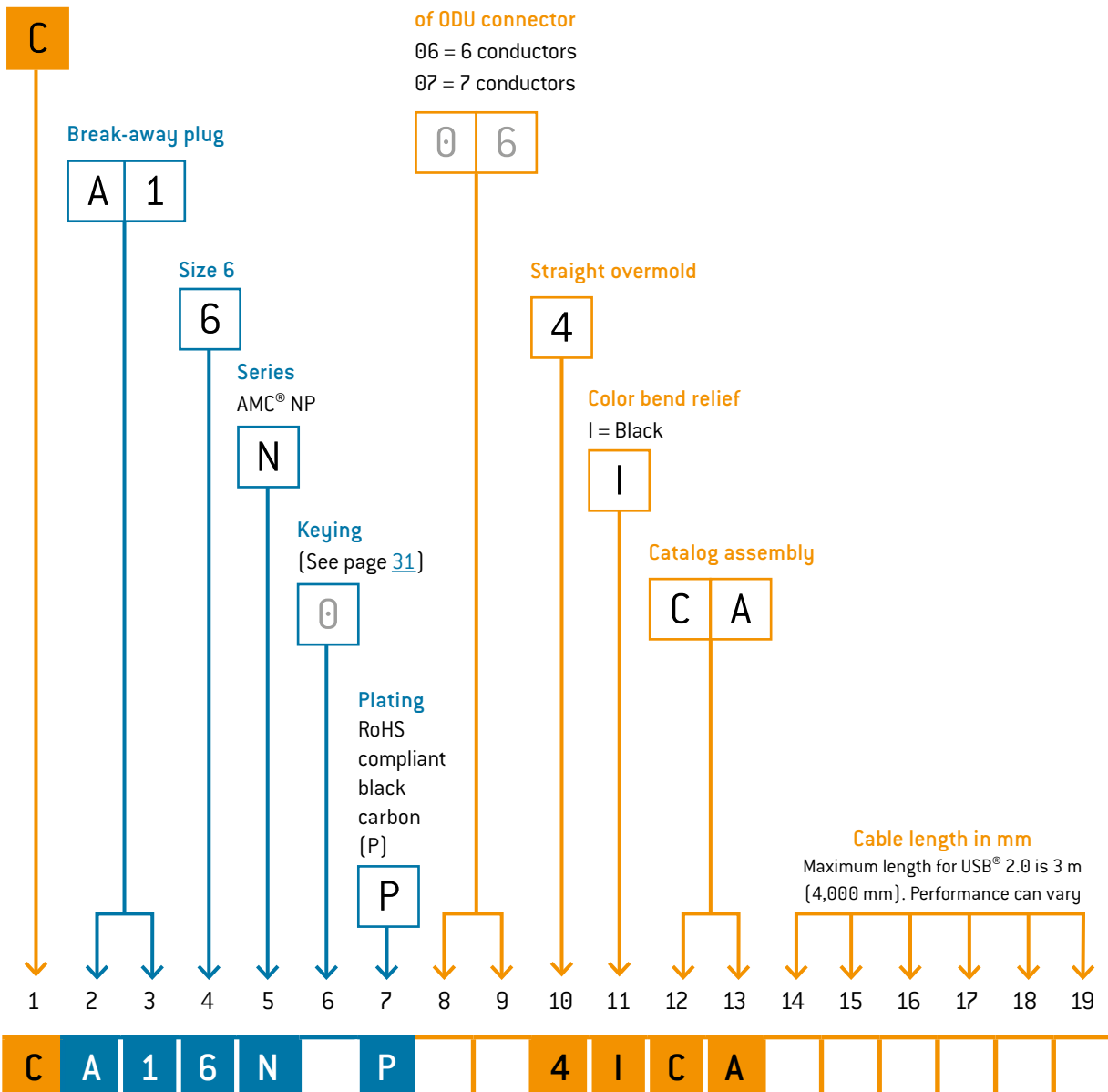

CABLE ASSEMBLY – IN-LINE RECEPTACLE – SOLDER

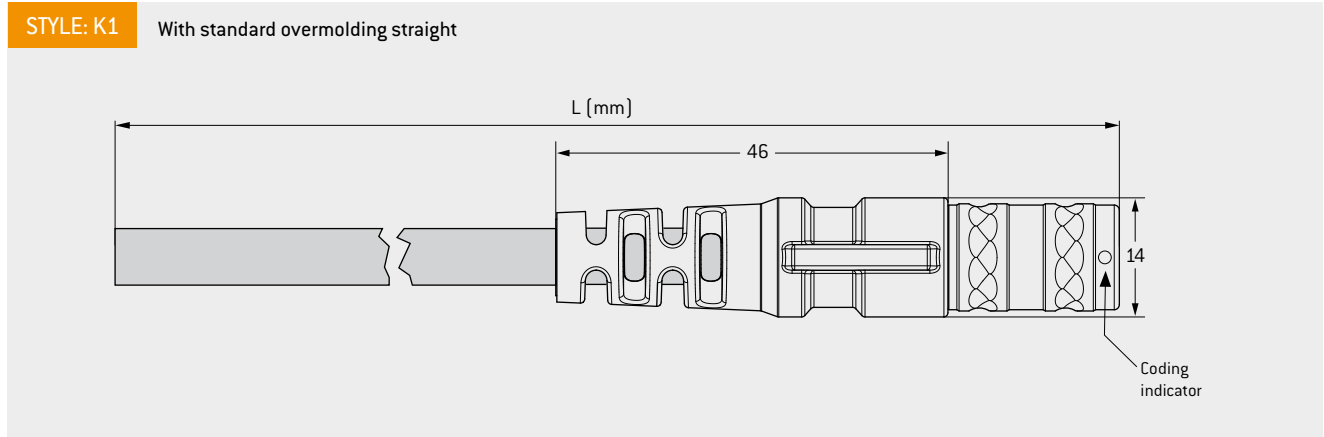

Cable assembly

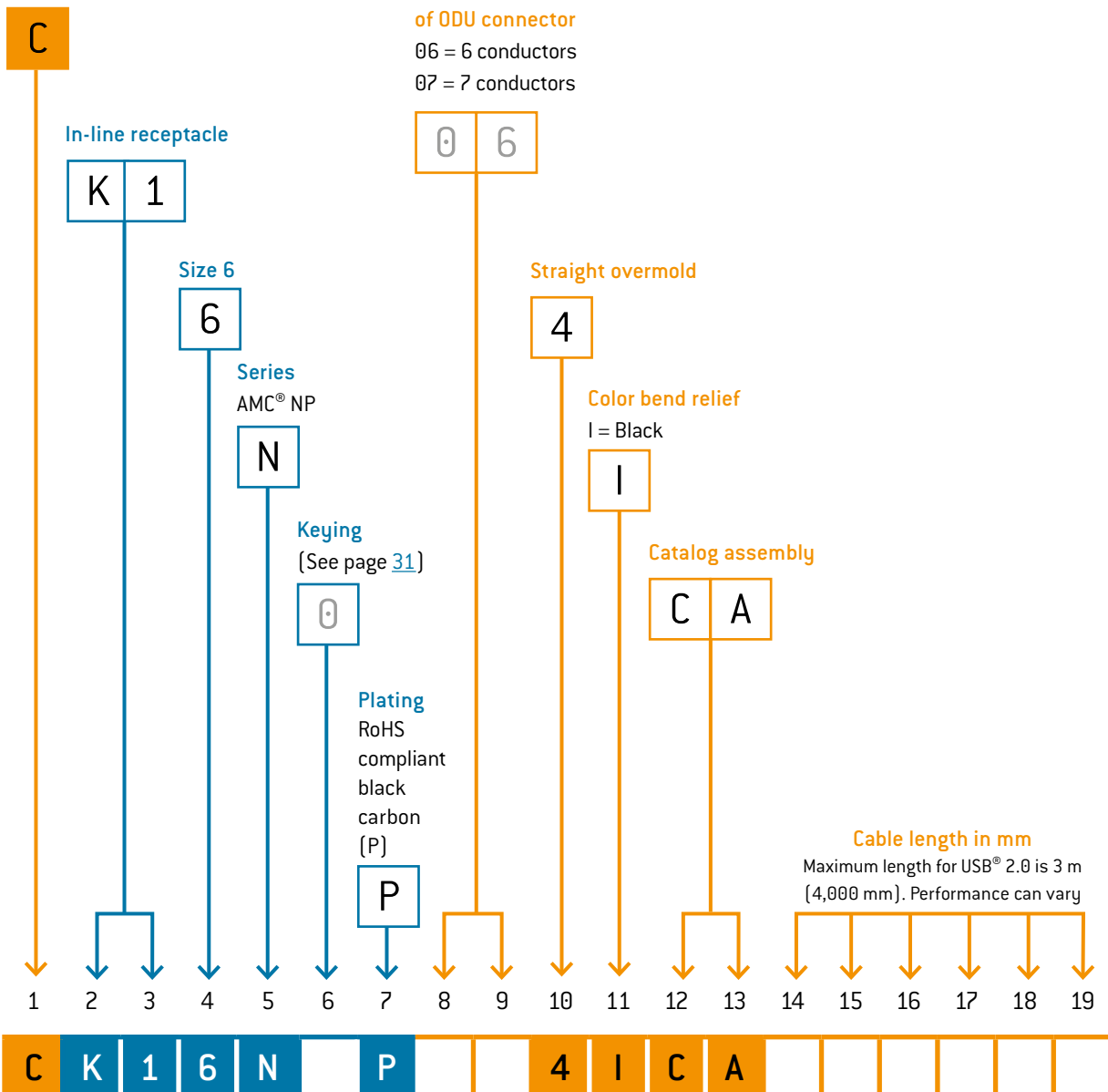

CABLE ASSEMBLY – IN-LINE RECEPTACLE – SOLDER

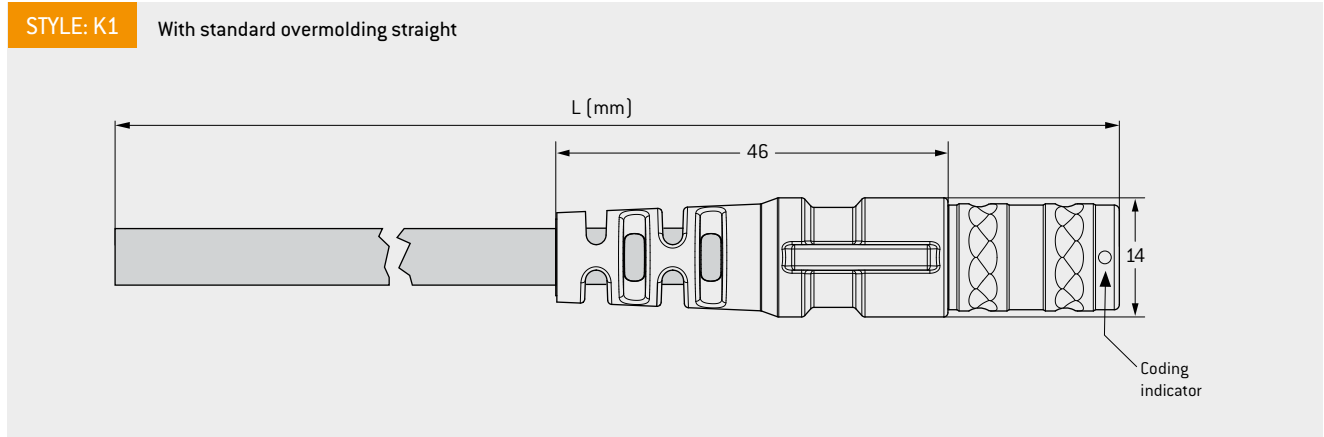

Cable assembly

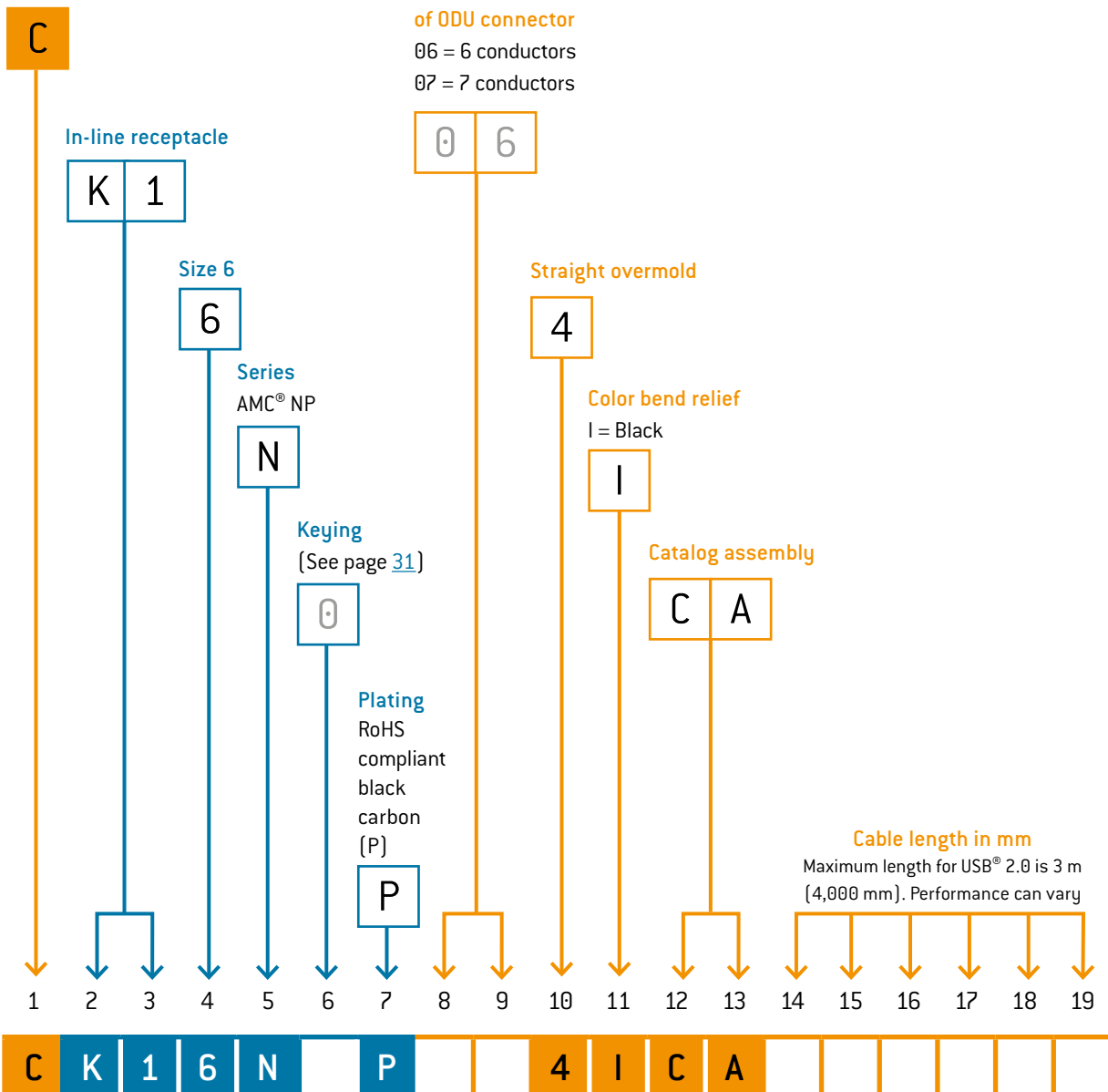

PANEL MOUNT RECEPTACLE – SOLDER OR PCB

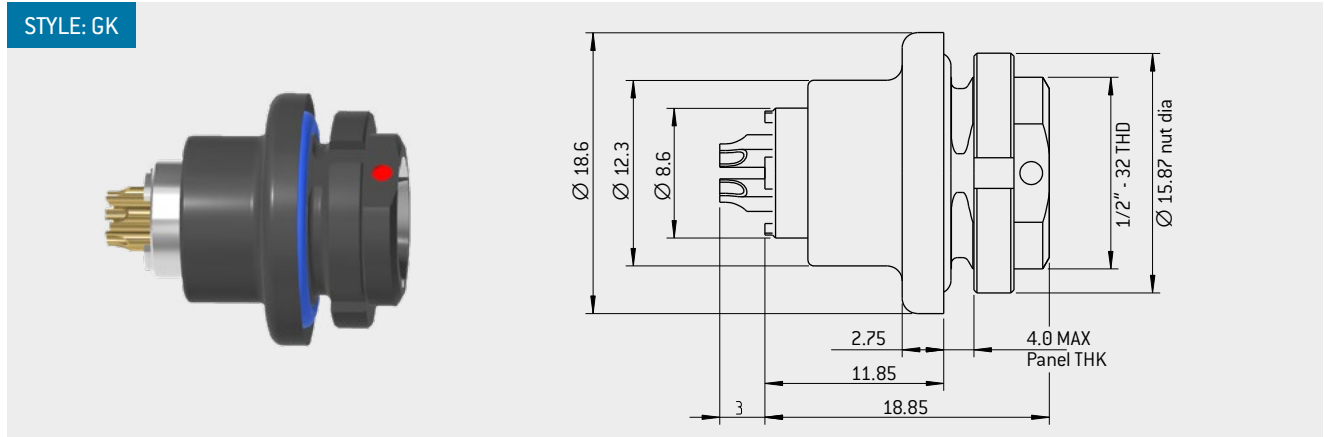

Panel mount receptacle

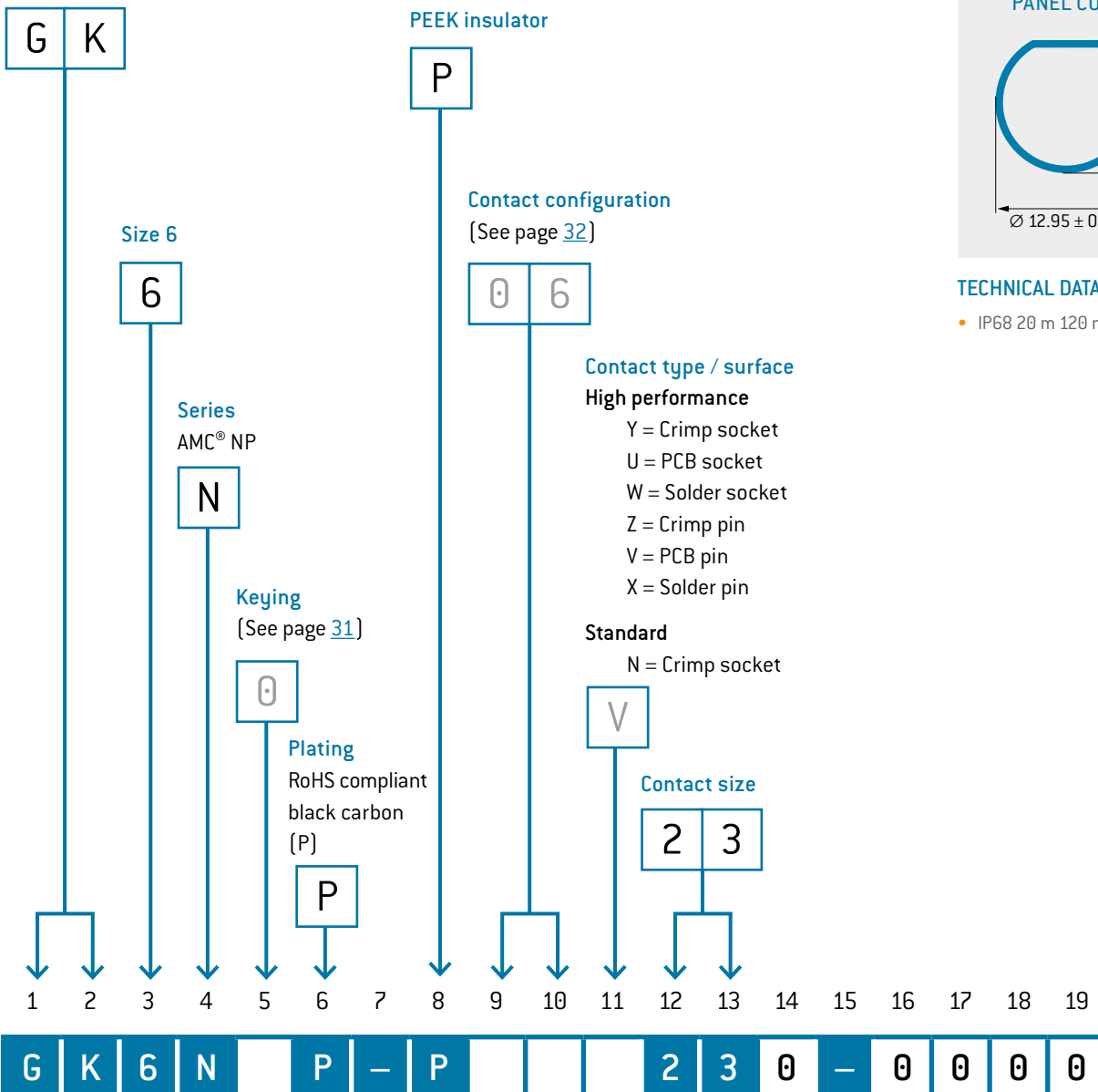

CABLE ASSEMBLY PANEL-MOUNT RECEPTACLE – SOLDER

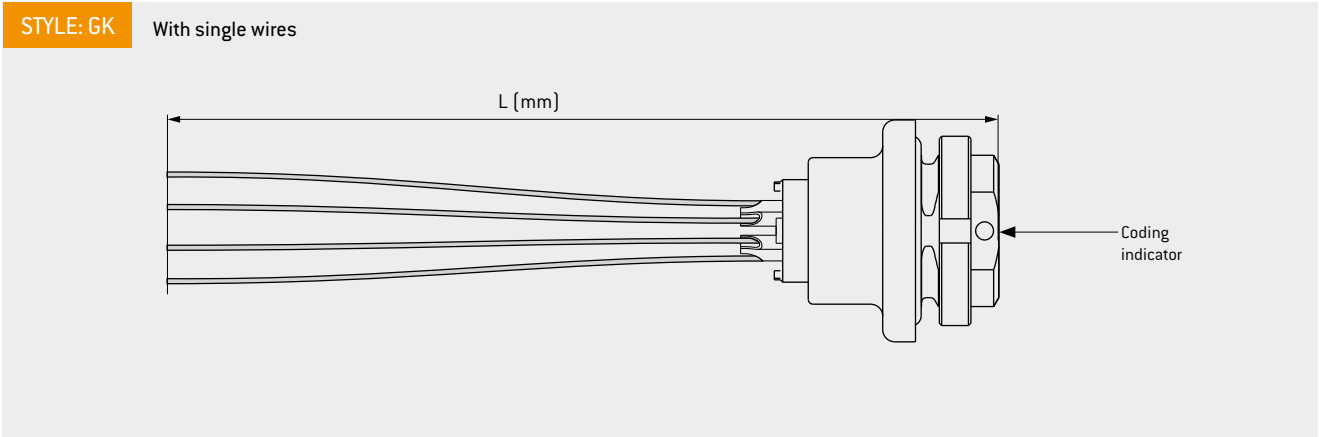

Cable assembly

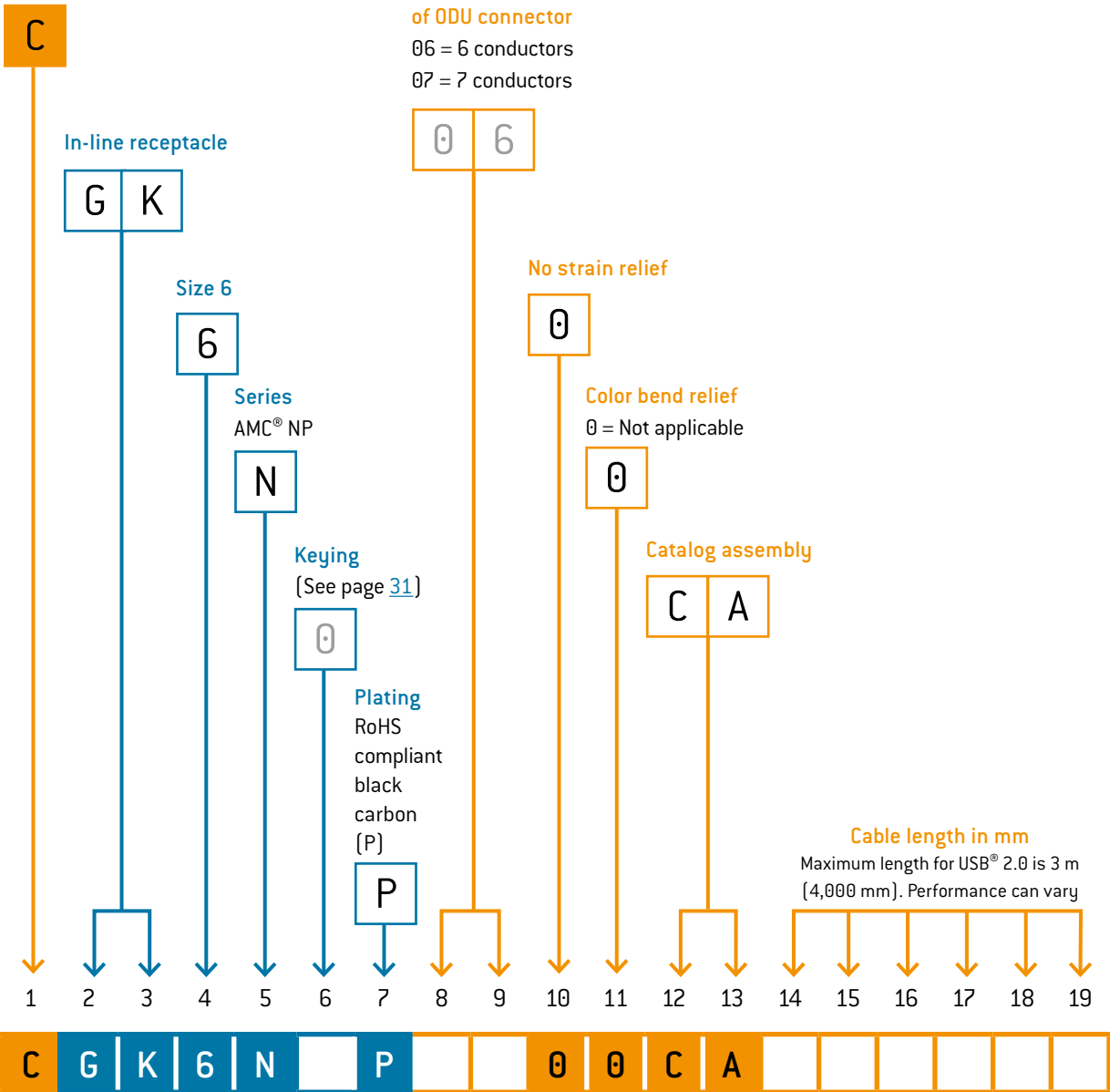

FLANGE MOUNT RECEPTACLE – NO HOLES SOLDER OR PCB

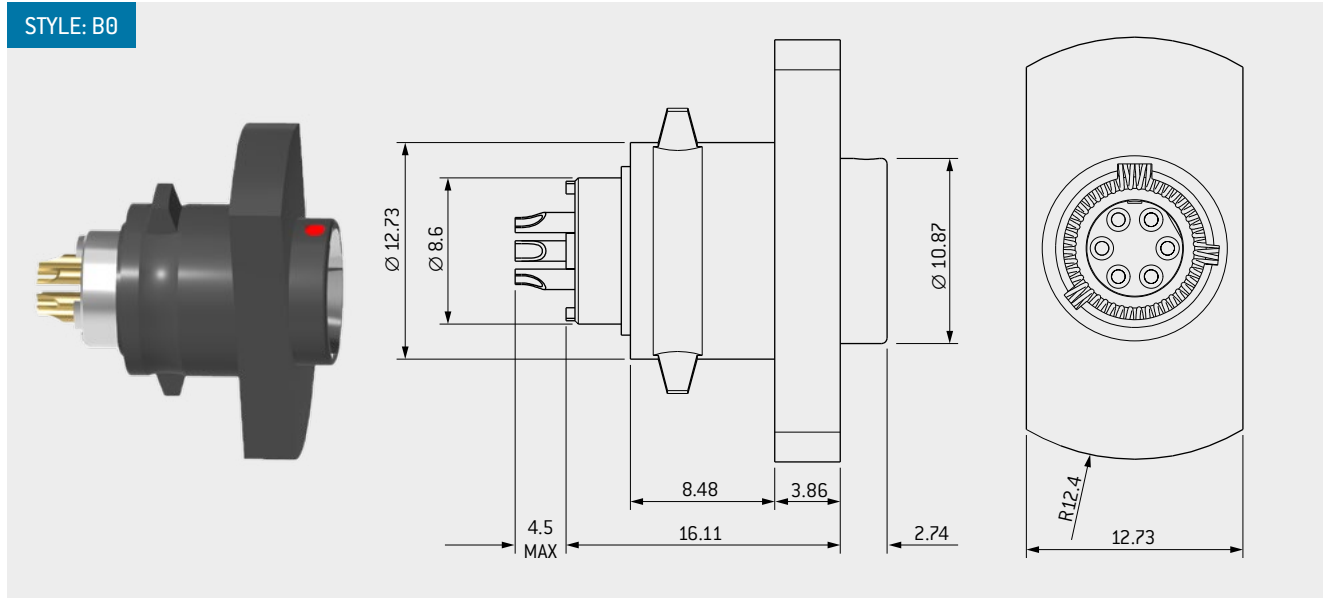

Bulkhead flanged receptacle

TECHNICAL DATA

- IP68 20 m 120 min
- No sealing to Bulkhead

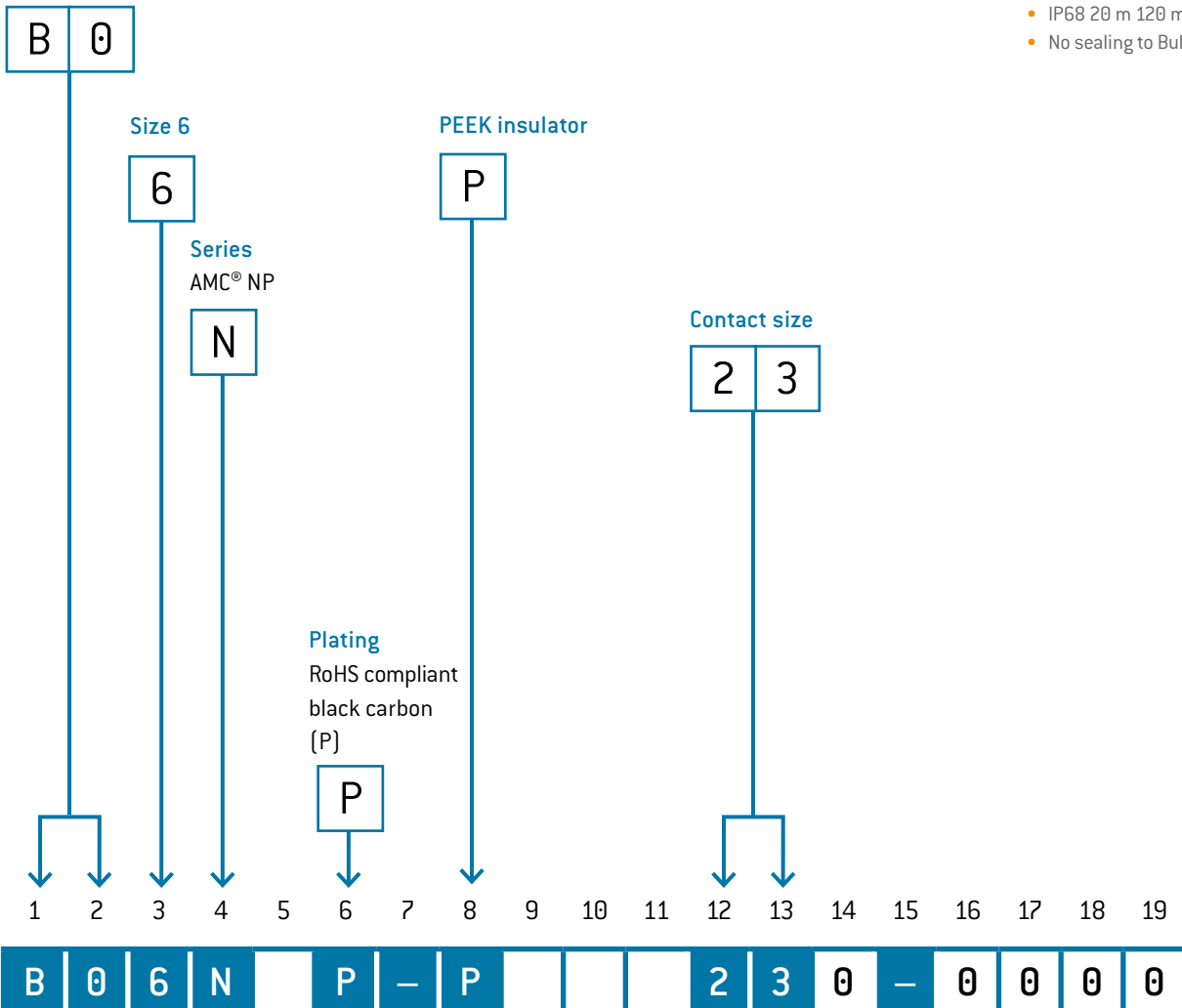

KEYING OPTIONS

NP KEYING GUIDE

Keying	A°	B°
Ø	95	230
A	150	210
B	75	210
D	140	275
E	75	275
F	95	210
G	165	195
H	140	220
J	115	245
K	105	205
L	155	255

Ø and G keyway standard catalog. All others please consult factory

PLUG

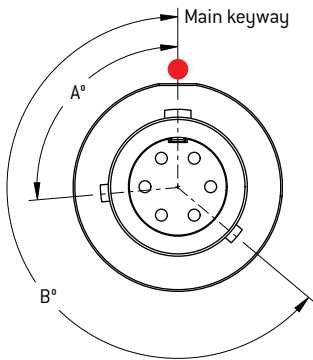

RECEPTACLE

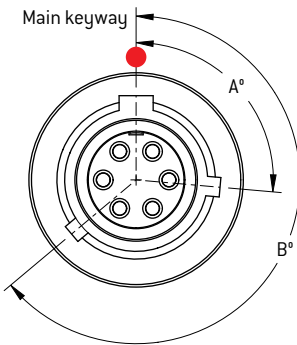

HOUSING MATERIAL

	Housing Material
P	RoHS compliant black carbon

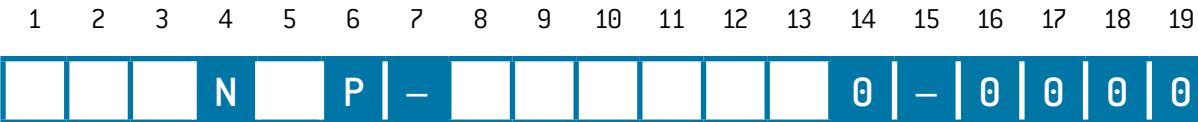

CONTACT INSERTS AND PCB LAYOUTS

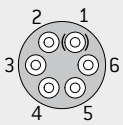
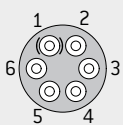
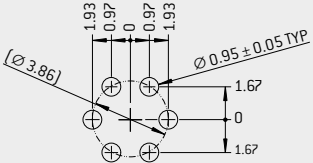
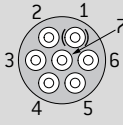
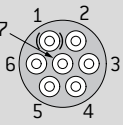
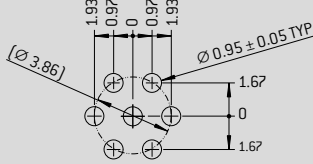
View on termination area		Data transmission protocols	PCB layout (view in mating direction)
Pin side	Socket side		
		USB®2.0	
		USB®2.0	

¹ Suitable wire (size and characteristics) considering the derating factor on page 51.

² Acc. to EIA-364-20F:2019-02 further information on voltage rating on page 46.



ODU AMC® NP

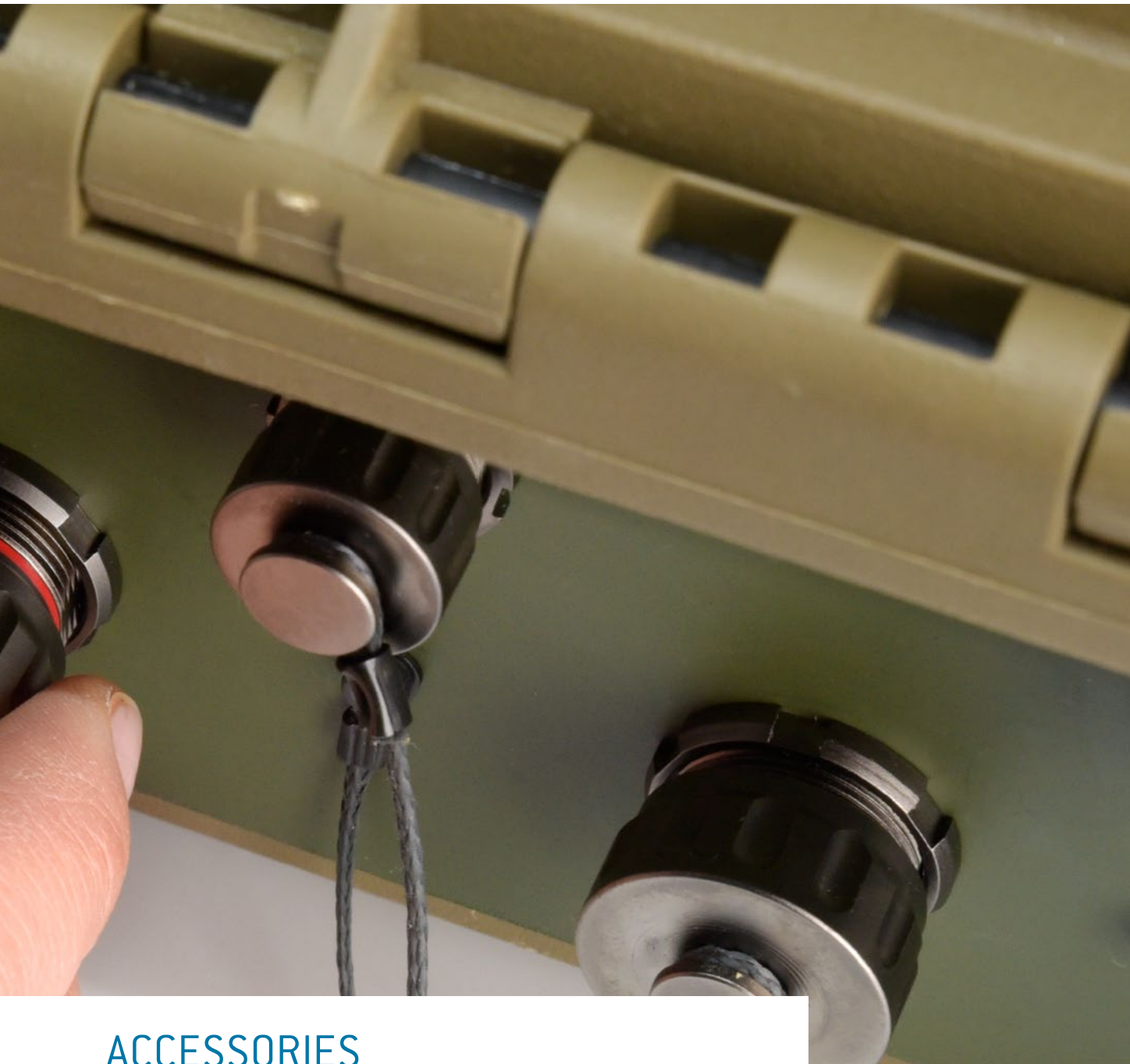

ACCESSORIES

Protection caps	36
Custom parts.....	37

ACCESSORIES – PROTECTIVE CAPS

MATES WITH STYLE A1

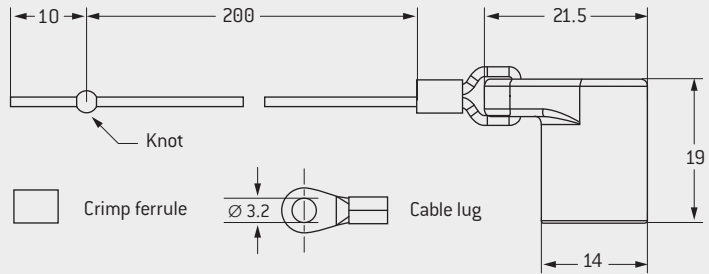

ODU Number

7N6.297.001.945.000

MATES WITH STYLE K1

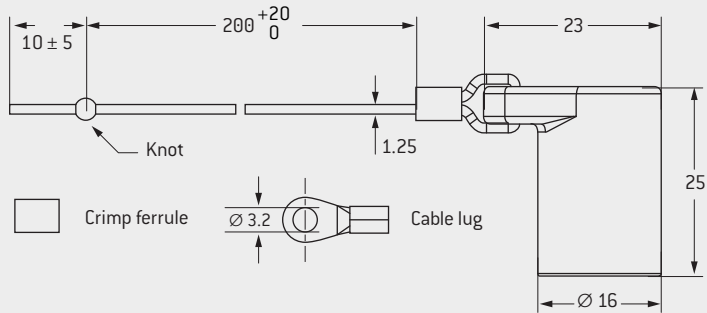

ODU Number

7N6.197.001.945.000

MATES WITH STYLE GK

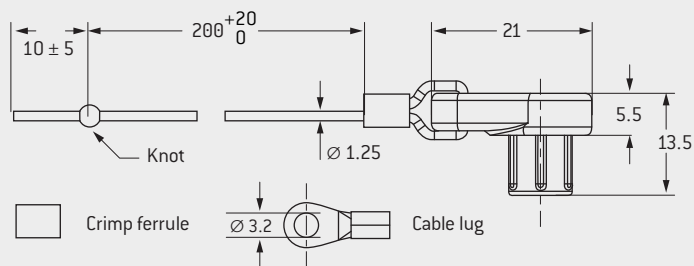

ODU Number

7N6.097.001.945.000

Crimp ferrule and lug are included.

¹ Assembly information including tools see ODU instruction 010.650.001.000.003 (available at www.odu-connectors.com/downloads/).

CUSTOM PARTS



40 POSITIONS / SIZE 1.5

- Ø 16.8 mm and a panel cut-out of Ø 14 mm
- Special cable assembly and potting needed



ROBUST, MINIATURE, LOW SPACE

- Miniature connector
- Reduced outside dimension Ø 6.5 mm



MINIATURE COAX CONNECTOR WITH SCREW LOCKING

- Cable assembly straight and right-angle
- Watertight



ODU AMC® HIGH-DENSITY WITH CUSTOMIZED CABLE ASSEMBLY

- Space saving cable assembly and overmolding



CUSTOMIZED LOW PROFILE SOLUTION

- Very small receptacle with chrome surface
- Plug with special customized design
- Very space saving overmolding and cable assembly
- Space saving 90° overmolding and cable assembly



- Space saving 90° cable assembly and overmolding
- Max. 6 positions



ODU AMC® NP



TOOLS

Banding tools.....	40
Contact crimp tools	40
Insertion and removal tools	40
Nutdriver for slotted nut	41
Heat shrink	41
Complete your connector system	41

TOOLS

BANDING TOOL

ODU Number	Name	Shell size
080.000.058.000.000	Band-it tool	universal



CONTACT CRIMP TOOLS

ODU Number	Name	Contact size
080.000.072.000.000	Digital contact crimp tool	#23

For further information see: [ODU Crimp instruction 080.000.072.000.000](#)



ODU Number	MIL-Part No.	Name	Contact size
080.000.075.000.000	M22520/2-01	Contact crimp tool	#23



POSITIONER

ODU Number	Name	Contact size
080.000.075.101.000	Positioner	#23



INSERTION / REMOVAL TOOL

ODU Number	MIL-Part No.	Name	Contact size
085.613.100.100.000	M81969/1-05	Insertion / removal tool	#23



NUT DRIVER FOR SLOTTED NUT

ODU Number	Name	Shell size
7N6.098.001.000.000	Nut driver	06



HEAT SHRINK STRAIGHT BOOT

ODU Number	Name	Cable diameter	Shell size
921.000.010.008.103	Heat shrink boot	> 3 mm	06

For a better adhesion of the heatshrink boots on housing and cable, ODU recommends to work with an adhesive epoxy. Hellermann V9500, TE Connectivity S1125. (Follow Hellermann / TE Connectivity work instructions)



HEAT SHRINK RIGHT ANGLE BOOT

ODU Number	Name	MIL type	Cable diameter	Shell size
921.000.010.008.103	Heat shrink right angle boot	1108-4	> 3.8 mm	06

For a better adhesion of the heatshrink boots on housing and cable, ODU recommends to work with an adhesive epoxy. Hellermann V9500, TE Connectivity S1125. (Follow Hellermann / TE Connectivity work instructions)



MICRO BANDS

ODU Number	Name	MIL type	Shell size
921.000.004.000.248	Micro bands	M85049/128-7	06

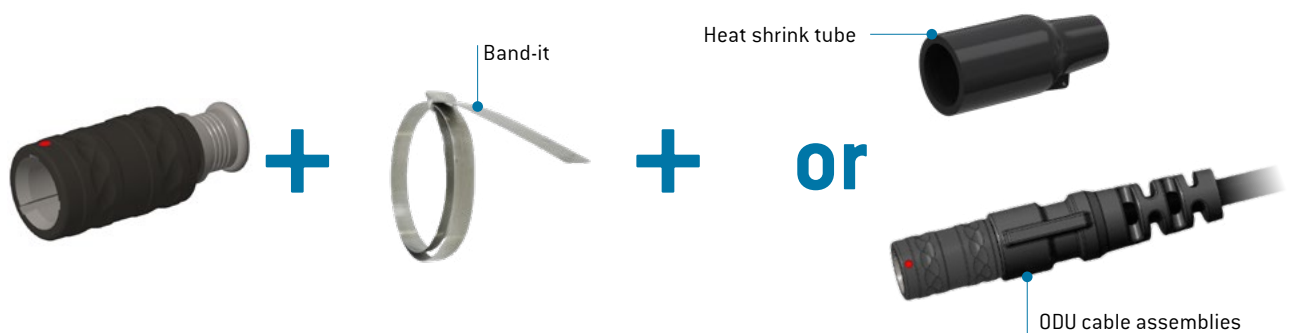

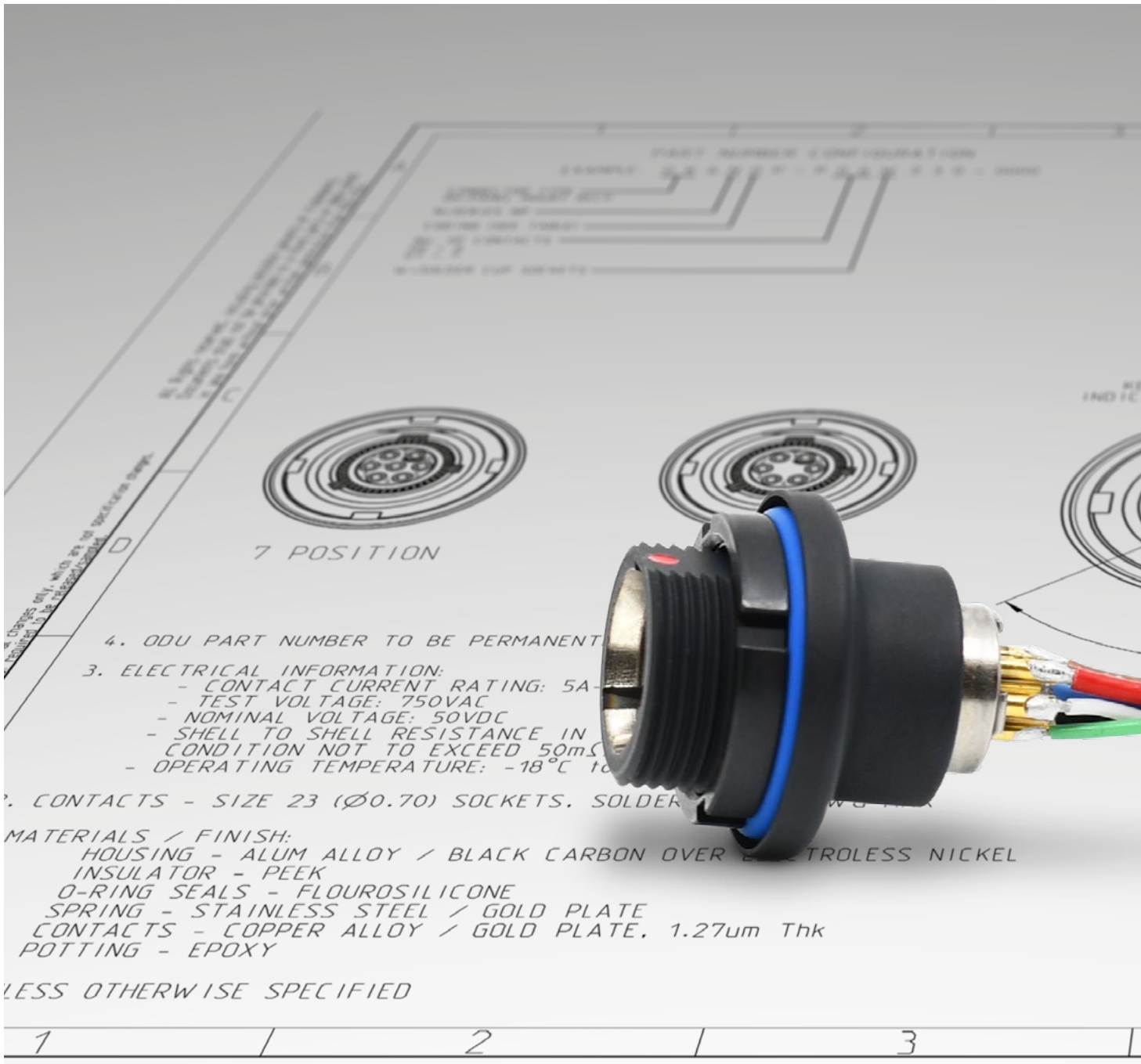

ODU AMC® NP

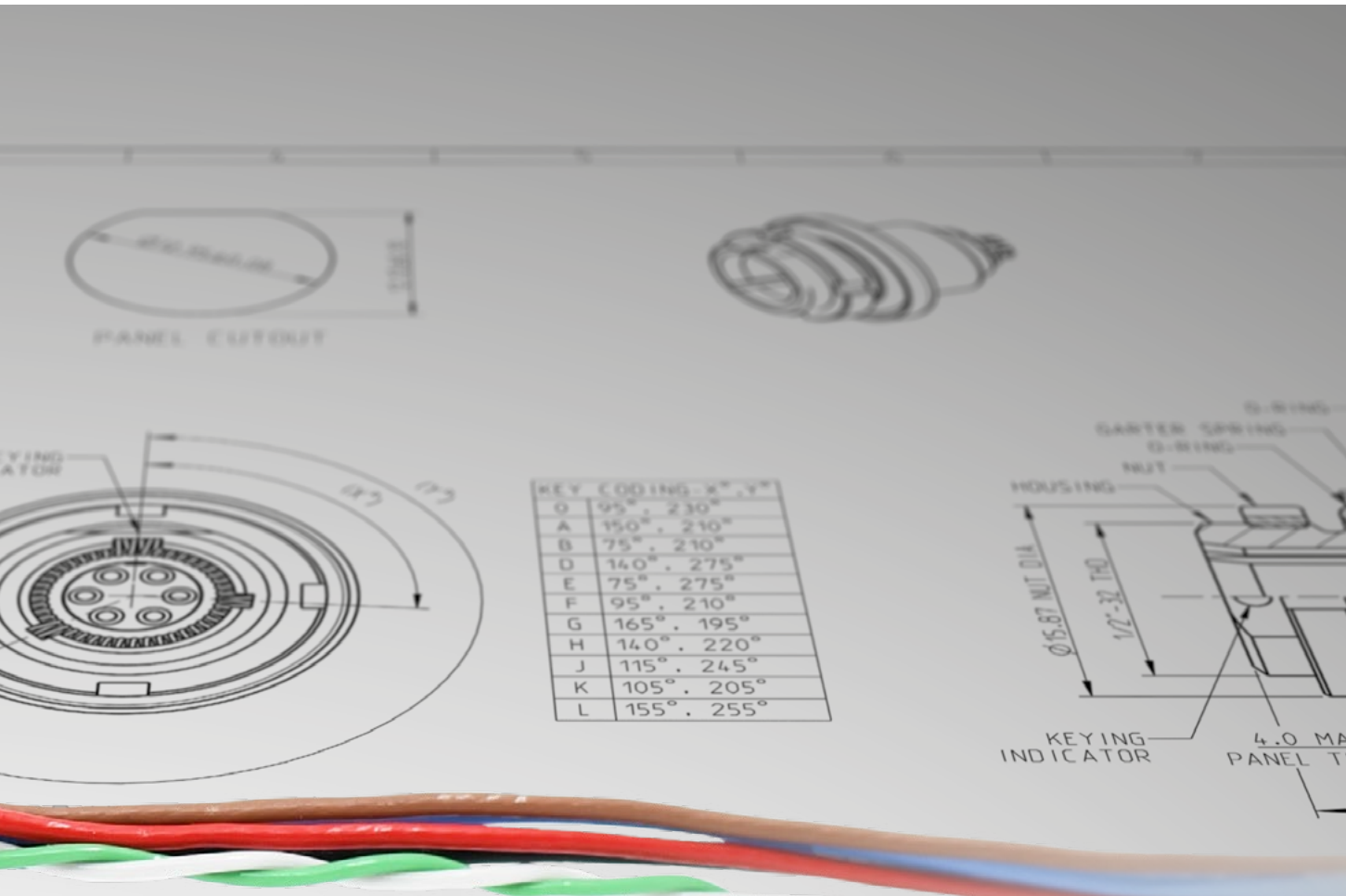

KEY CODING	α°	β°
O	95°	230°
A	150°	210°
B	75°	210°
D	140°	275°
E	75°	275°
F	95°	210°
G	165°	195°
H	140°	220°
J	115°	245°
K	105°	205°
L	155°	255°

			Descri
			EC-No.:
General tol.: DIN ISO 2768-mH Tolerancing: DIN ISO 8015 State:		Revision:	Dr
Prepared	03.06.2022	pbair	- M
Changed	17.08.2022	pbair	
Released			
		Name	
			6

TECHNICAL INFORMATION

- Technical data – ODU AMC® NP [44](#)
- International protection classes [50](#)
- Conversions / AWG [51](#)
- International color code / IC-code [52](#)
- Technical terms [53](#)

TECHNICAL DATA – ODU AMC[®] NP CONNECTORS



OPTIMIZED
FOR HARSH
ENVIRONMENTS



ENVIRONMENTAL AND TESTING

Description	Requirement	Procedure
Tightness (Crimp)	IP65	MIL-STD-810H Method 512.5 ISO 20653:2013-02
Tightness (Solder)	IP68 / 20 m 120 min	MIL-STD-810H Method 512.5 ISO 20653:2013-02
Altitude	Fully operable at all altitudes from sea level to 9,754 meters (32,000 feet)	MIL-STD-810H Method 500.6 Procedures I (storage), II (operation) and III (rapid decompression)
High temperature	Continuous, ambient temperature of +55 °C (130 °F) Conduct three (3) 24-hour cycles	MIL-STD-810H Method 501.7 Procedures II (operation)
	Storage temperature of +71 °C (160 °F) Conduct seven (7) 24-hour cycles	MIL-STD-810H Method 501.7 Procedures I (storage)
Low temperature	Continuous temperature of –18 °C (0 °F). Duration of the test is 6 hours	MIL-STD-810H Method 502.7 Procedure II
Solar radiation	Cycle A1, for three (3) continuous cycles	MIL-STD-810H Method 505.7 Procedure I
Humidity	Cycle B2, six (6) 24-hour test cycles	MIL-STD-810H Method 505.7 Procedure I
Snow and ice	Perform the glaze ice procedure for 6-millimeter ice thickness	MIL-STD-810H Method 521.4
Salt atmosphere	Two (2) 24-hour cycles	MIL-STD-810H Method 509.7
Sand and dust	Procedure I: Air velocity of 8.9 m/s, Temperature of +55 °C Duration is 6 hours Procedure II: Air Velocity 18 m/s, Temperature is +55 °C Sand concentration of 2.2 + 0.5 g / m ³ Duration is 30 min each face	MIL-STD-810H Method 510.7 Procedures I and II
Mud, sand and dirt	Connector shall function when exposed to mud, sand, and dirt	Verification, basic functionality test
Rain and water	The rainfall rate is at least 10 cm/hr (4 inch / hr). The wind velocity is 18 m/s (40 mi / hr). Functional verification during the last 10 minutes of the 30-minute rain cycle	MIL-STD-810H Method 506.6 Procedure I

TECHNICAL DATA – ODU AMC® NP CONNECTORS

ELECTRICAL DATA

Description	Requirement			Procedure
Electrical capacity	Contact size #23	Current 7.5 A		EIA-364-70D:2021-05 ¹ Nett Warrior At 16 VDC for 30 minutes Connector temperature does not increase more than 20° F from ambient temperature
	#23	5.0 A		
Continuity	EMI/EMC requirements to meet 50 V / meter conditions or higher. Electrical continuity of pin to socket and shell-to-shell shall be less than 0.05 Ohms. Insulation resistance shall be greater than 100 M Ohms with an applied voltage of 500 VDC for 1 second			MIL-STD-461G
EMI / EMC	50 Volts / meter across a span of 2-10,000 MHz			MIL-STD-461G Procedures RE102 and RS103
Shell to shell resistance	< 50 m Ohms			Verification
DWV at sea level	Contact size #23	DWV 750V AC		EIA-364-20F:2019-02
Operating voltage	< 50 VAC			EIA-364-20F:2019-02
Insulation resistance	The insulation resistance between any pair of contacts and between any contact and the shell shall be greater than 5,000 MΩ			EIA-364-21F:2020-07
Low level contact resistance	Wire size		Contact resistance	EIA-364-23D:2022-07
	22		15 mOhm	
	24		20 mOhm	
	26		31 mOhm	
	28		50 mOhm	
Contact resistance, voltage drop	Wire size (AWG)	Test current	Max. Voltage drop	EIA-364-06C:2012-04
	22	5 A	75 mV	
	24	3 A	75 mV	
	26	2 A	75 mV	
	28	1.5 A	75 mV	
USB® 2.0	480 Mbps up to 3 m ²			Verification, basic functionality test

¹ Please consult factory for verification data

² Cable length depends on cable selection of customer

MECHANICAL DATA

Description	Requirement	Procedure		
Break-away force	13 +/- 3 pounds	Verification		
Cable assembly strength	100 pound pull force static force 30 seconds	Verification, basic functionality test		
Chemical safety	Materials used in the connectors shall not create a toxic health hazard	Verification of materials		
Shock	Figure 516.8-3, where Am = 40 g and TD = 11 ms No discontinuity of greater than 1 microseconds, no cracking, breaking or loosening of parts, plug shall not become disengaged from receptacle	MIL-STD-810H Method 505.7 Procedure I		
Vibration	Longitudinal and radial orientations for one hour each	MIL-STD-810H Method 514.8 Annex E Procedure I		
	Loose Cargo vibration test Category 5 for 20 minutes	MIL-STD-810H method 514.8 procedure II		
Insert retention	111N Insert shall retain in their proper location. No evidence of cracking, breaking, separation from the shell or loosening parts	EIA-364-35C:2012-04		
Electrical engagement	Mated connectors shall provide a minimum of .050 inch (1.27 mm) electrical engagement	MIL-DTL-38999M, para. 4.5.15		
Contact retention	<table border="1" style="width: 100%; border-collapse: collapse;"> <tr> <td style="text-align: center;">Contact size #23</td> <td style="text-align: center;">Min. force 6 lbs (26.7 N)</td> </tr> </table>	Contact size #23	Min. force 6 lbs (26.7 N)	EIA-364-29:2019-05
	Contact size #23	Min. force 6 lbs (26.7 N)		
Minimum axial load force shall not displace contacts more than .012 inches (.305 mm)				
Durability	2,000 cycles No mechanical or electrical defects detrimental to the operation of the connector after the specified number of cycles of mating and unmating	MIL-DTL-38999M, para. 4.5.8.2		
Marking	Each connector shall include clearly readable part number and manufacturer information	Verification		













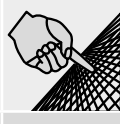

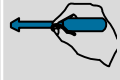
MATERIAL AND SURFACE TREATMENTS

Component	Material	Standard		Surface	Standard	Flammability
		EU	US			
Housing / nut	aluminum AlMgSiSn1Bi	EN-AW 6023		Black carbon over nickel		
Insulator	PEEK (solder contacts) or LCP (crimp contacts)					UL94 (V0)
O-ring	fVMQ (fluorosilicone)					
Spring	stainless steel			Gold		
Seals	fVMQ (fluorosilicone)					
Pin contact ODU specific Solder / PCB	CuNi1Pb1P (K41/ C97)		C19160	1.27 µm gold over nickel	ASTM B 488:2018 Type II, C	
Socket contact ODU specific Solder / PCB	CuNi1Pb1P (K41/ C97)		C19160	1.27 µm gold over nickel	ASTM B 488:2018 Type II, C	
Pin contact MIL standard High performance crimp	CuPb1P (C99)		C18700	1.27 µm gold over nickel	ASTM B 488:2018 Type II, C	
Socket contact MIL standard Crimp	CuNiPb1P (C97)		C19160	1.27 µm gold over nickel	ASTM B 488:2018 Type II, C	
	Stainless steel (sleeve)					
Potting (solder contacts)	Potting compound					UL94 (V0)
Overmolding material	TPU					UL94 (HB)
Contact retention clip	CeBu		C17200			

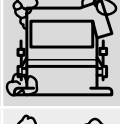

INTERNATIONAL PROTECTION CLASSES

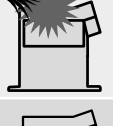
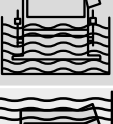
ISO 20653:2013-02

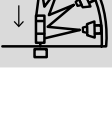
Code letters (International Protection)		First code number (Degrees of protection against access to hazardous parts respectively against solid foreign objects)		Second code number (Degrees of protection against water)		
IP		6		5		
Code no.	Protection against access to hazardous parts / Protection against ingress of solid foreign objects			Code no.	Protection against harmful effects due to the ingress of water	
0	No protection		No protection against contact / No protection against solid foreign objects	0	No protection against water	No protection against water
1	Protection against contact with the back of hand (no protection against intentional contact)		Test probe with diameter 50 mm shall not penetrate completely and maintain sufficient distance from hazardous parts.	1	Protection against dripping water	 Vertical drips shall not have any harmful effects or impair performance.
2	Protection against finger contact		Jointed test finger with diameter 12.5 mm may penetrate completely, but shall maintain a sufficient distance from hazardous parts.	2	Protection against dripping water (tilted)	 Vertical drips shall not have any harmful effects or impair performance when the enclosure is tilted at any angle up to 15° on either side of the vertical
3	Protection against penetration of tools (e.g. screwdrivers)		Test probe with diameter 2.5 mm, may penetrate completely, but shall maintain a sufficient distance from hazardous parts.	3	Protection against spray water	 Water spray at an angle up to 60° on either side of the vertical shall have no harmful effects or impair performance
4	Protection against granular foreign objects		Test probe with diameter 1.0 mm, may penetrate completely, but shall maintain a sufficient distance from hazardous parts	4	Protection against splashing water	 Water which splashes against the enclosure from any direction shall not have any harmful effects or impair performance
				4K	Protection against splashing water with increased pressure	 Water which splashes against the enclosure from any direction with increased pressure shall not have any harmful effects or impair performance
5K	Protection against dust		Dust shall only penetrate in quantities which do not impair performance and safety.	5	Protection against high-velocity water	 Water which is directed against the enclosure from any direction as a jet shall not have any harmful effects or impair performance
6	Dustproof		Protection against contact with a wire / Complete protection against ingress of dust	6	Protection against powerful water jet	 Water which is directed against the enclosure from any direction as a strong jet shall not have any harmful effects or impair performance
6K	Protection against ingress of dust		Dust shall not penetrate	6K	Protection against strong high-velocity water with increased pressure	 Water which is directed against the enclosure from any direction as a strong jet with increased pressure shall not have any harmful effects or impair performance
				7	Protection against the effects of temporary immersion in water	 Water shall not penetrate in a quantity causing harmful effects or impair performance if the enclosure is immersed in water temporarily under specified pressure and time conditions
				8	Protection against the effects of continuous immersion in water	 Water shall not penetrate in a quantity causing harmful effects if the enclosure is continuously immersed in water under conditions which shall be specified by the manufacturer
				9K	Protection against water during high-pressure/steam-jet cleaning	 Water which is directed against the enclosure from any direction shall not have any harmful effects or impair performance

CONVERSIONS / AWG (AMERICAN WIRE GAUGE)

Circular wire					
AWG	Diameter		Cross-section mm ²	Weight kg / km	Max. resistance Ω / km
	Inch	mm			
10 (1)	0.1019	2.590	5.26	46.77	3.45
10 (37/26)	0.1150	2.921	4.74	42.10	4.13
12 (1)	0.0808	2.050	3.31	29.41	5.45
12 (19/25)	0.0930	2.362	3.08	27.36	6.14
12 (37/28)	0.0910	2.311	2.97	26.45	6.36
14 (1)	0.0641	1.630	2.08	18.51	8.79
14 (19/27)	0.0730	1.854	1.94	17.23	9.94
14 (37/30)	0.0735	1.867	2.08	18.870	10.50
16 (1)	0.0508	1.290	1.31	11.625	13.94
16 (19/29)	0.0590	1.499	1.23	10.928	15.70
18 (1)	0.0403	1.020	0.823	7.316	22.18
18 (19/30)	0.0052	1.321	0.963	8.564	20.40
20 (1)	0.0320	0.813	0.519	4.613	35.10
20 (7/28)	0.0390	0.991	0.563	5.003	34.10
20 (19/32)	0.0420	1.067	0.616	5.473	32.00
22 (1)	0.0253	0.643	0.324	2.883	57.70
22 (7/30)	0.0288	0.732	0.324	2.965	54.80
22 (19/34)	0.0330	0.838	0.382	3.395	51.80
24 (1)	0.0201	0.511	0.205	1.820	91.20
24 (7/32)	0.0250	0.635	0.227	2.016	86.00
24 (19/36)	0.0270	0.686	0.241	2.145	83.30
26 (1)	0.0159	0.404	0.128	1.139	147.00
26 (7/34)	0.0200	0.508	0.141	1.251	140.00
26 (19/38)	0.0220	0.559	0.154	1.370	131.00
28 (1)	0.0126	0.320	0.0804	0.715	231.00
28 (7/36)	0.0160	0.406	0.0889	0.790	224.00
28 (19/40)	0.0170	0.432	0.0925	0.823	207.00
30 (1)	0.0100	0.254	0.0507	0.450	374.00
30 (7/38)	0.0130	0.330	0.0568	0.505	354.00
30 (19/42)	0.0123	0.312	0.0720	0.622	310.00
32 (1)	0.0080	0.203	0.0324	0.288	561.00
32 (7/40)	0.0110	0.279	0.0341	0.303	597.10
32 (19/44)	0.0100	0.254	0.0440	0.356	492.00
34 (1)	0.0063	0.160	0.0201	0.179	951.00
34 (7/42)	0.0070	0.180	0.0222	0.197	1,491.00
36 (1)	0.0050	0.127	0.0127	0.1126	1,519.00
36 (7/44)	0.0060	0.150	0.0142	0.1263	1,322.00

The American Wire Gauge (AWG) is based on the principle that the cross-section of the wire changes by 26 % from one gauge number to the next. The AWG numbers decrease as the wire diameter increases, while the AWG numbers increase as the wire diameter decreases. This only applies to solid wire.

However, stranded wire is predominately used in practice. This has the advantage of a longer service life under bending and vibration as well as greater flexibility in comparison with solid wire.

Stranded wires are made of multiple, smaller-gauge wires (higher AWG number). The stranded wire then receives the AWG numbers of a solid wire with the next closest cross-section to that of the stranded wire. In this case, the cross-section of the stranded wire refers to the sum of the copper cross-sections of the individual wires.

Accordingly, strands with the same AWG number but different numbers of wires differ in cross-section. For instance, an AWG 20 strands of 7 AWG 28 wires has a cross-section of 0.563 mm², while an AWG 20 strand of 19 AWG 32 wires has a cross-section of 0.616 mm².

DERATING FACTOR

Number of loaded wires	Derating factor
5	0.75
7	0.65
10	0.55
14	0.50
19	0.45
24	0.40

Source: ASTM

MIL-STD-681F SYSTEM 1

INTERNATIONAL COLOR CODE / IC-CODE

For UL / CSA control cables

Core	Core color
1	Black
2	Brown
3	Red
4	Orange
5	Yellow
6	Green
7	Blue
8	Violet
9	Gray
10	White
11	White-Black
12	White-Brown
13	White-Red
14	White-Orange
15	White-Yellow
16	White-Green
17	White-Blue
18	White-Violet
19	White-Gray
20	Brown-Black

- The cores are counted starting in the outer layer and continuing through all layers in the same direction. The first color is the base color.
- For cables with color repetition, the color code starts again with Black(1).
- For paired cores, always the two colors named in sequence are stranded.

TECHNICAL TERMS

AMBIENT TEMPERATURE

Temperature of the air or other medium in which a connector or a corresponding cable assembly is intended to be used.

AWG

American Wire Gauge (see page [51](#)).

CHEMICAL RESISTANCE

Chemical resistance is the ability of a material to protect itself against chemical attack or solvent reaction. In contrast to corrosion, there is no material removal, which is particularly typical for plastics and elastomers.

Adhesives, cleaning agents or other chemicals are often used on our products within the scope of general deployment and further handling. Contact with unsuitable chemicals may have an adverse effect on the mechanical and electrical properties of the insulation and housing materials. The connector specifications may no longer be sustainable. Please observe our handling suggestions and technical instructions as given in this catalog or corresponding assembly instructions.

CLEARANCE DISTANCE

The shortest distance by air between two conductive parts.

CODING (MECHANICAL)

Geometry detail that prevents interchangeability of otherwise identical connectors. This is useful when two or more identical connectors are attached to the same device.

CONNECTOR WITH BREAKING CAPACITY (COC)

Connector that may be mated or unmated during intended use, live or under load (according to IEC 61984:2008 [VDE 0627:2009-11]).

CONNECTOR WITHOUT BREAKING CAPACITY (COC)

Connector which is not deemed to be engaged or disengaged in normal use when live under load (according to IEC 61984:2008 [VDE 0627:2009-11]).

CONNECTORS

An element which enables electrical conductors to be connected and is intended to create and/or separate connections with a suitable counterpart (according to IEC 61984:2008 [VDE 0627:2009-11]). If not otherwise specified, these are connectors without breaking capacity (COC).

CONTACT RESISTANCE

The contact resistance is the contact resistance at the contact zone of an electrical contact pair. The contact resistance is significantly lower than the total resistance (refer to total resistance). The specifications are average values.

CORES

Electrical conductor, solid wire or multi-wire strand, with insulation as well as any conductive layers. Cables or leads may have one or more cores.

CREEPAGE DISTANCES

The shortest distance between two conductive parts along the surface of a solid insulation material. This factors in all elevations and recesses in the insulator, as long as defined minimum dimensions are on hand.

CRIMP BARREL

A terminal sleeve which can accommodate one or more conductors and be crimped by a crimping tool.

CRIMP CONNECTION (CRIMP TERMINATION)

The permanent, non-detachable and solder-free mounting of a contact to a conductor via deforming or shaping under pressure to make a good electrical and mechanical connection. Executed with crimping tool, press or automatic crimping machine (see page [40](#)).

CRIMPING AREA

The specified area of the crimp barrel in which the crimp termination is executed by means of deforming or shaping the barrel under pressure around the conductor.

DELIVERY FORM

Connectors can be delivered in assembled form or as individual parts.

DERATING MEASUREMENT METHOD IN ACCORDANCE WITH IEC 60512-5-2:2002 (DIN EN 60512-5-2:2003-01)

According to VDE 0298-4:2013-06, with connectors and cables over 5 contacts, the heating is greater than it is with individual contacts. For that reason, the aforementioned standard is calculated with a derating factor.

TECHNICAL TERMS

INSERTION AND WITHDRAWAL FORCE

The force required to fully insert or withdraw pluggable elements without the influence of a coupling or locking device.

INSULATOR

Part of a connector that separates conductive parts with different potential, usually identical to the contact carrier.

MATING CYCLES

A mating cycle consists of one insertion and withdrawal action of both connector parts with each other. The given values are only valid under the following conditions: clean environment, adequate radial alignment, flawless counter contact pins.

NOMINAL VOLTAGE

The nominal voltage of the power source for which the connector is being used. The nominal voltage may not be higher than the rated voltage of the connector.

OPERATING TEMPERATURE

Permissible temperature range between the uppermost and lowermost limits. This includes contact heating through current-carrying capacity.

OPERATING VOLTAGE

The operating voltage is the voltage supply at the device. The operating voltage may not be higher than the rated voltage of the connector.

PCB TERMINATION

A conductive connection between the PCB and an element in through-hole assembly, THT (through-hole technology).

PRINTED CIRCUIT BOARD (PCB)

A PCB is a carrier for electronic components. It serves the purposes of mechanical mounting and electrical connection.

RATED CURRENT (NOMINAL CURRENT)

See from page [32](#).

RATED VOLTAGE

The rated voltage which the manufacturer specifies for a connector and which the operating and performance features relate to.

REDUCTION FACTOR

Based on VDE 0298-4:2013-06, connectors and cables with more than 5 contacts have a higher heating rate compared to individual contacts. For this reason, the aforementioned standard is calculated with a reduction.

SOLDER CONNECTION (SOLDER TERMINATION)

Termination technology in which a molten additional metal (solder) with a lower melting point than the base materials to be connected is used to attach two metallic materials to one another.

STRANDED WIRE

The stranded wire is an electrical conductor consisting of thin individual wires and is therefore easy to bend.

TERMINATION CROSS-SECTION

The specified cross-sections correspond to a "fine-wire" conductor structure (7/19 wire) according to AWG (ASTM B258-14) or to a "fine-wire" conductor structure pursuant to IEC 60228:2004 (VDE 0295:2005-09; Class 5), borderline conductor structures require a separate review.

TERMINATION TECHNOLOGIES

Methods for connecting the leads to the electro-mechanical element, such as solder-free connections pursuant to IEC 60352 (DIN EN 60352): crimp, screw connection etc. or soldering connection.

TEST VOLTAGE

The test voltage which a connector or a corresponding cable assembly can withstand under defined conditions without dielectric breakdown or flashover.

TIGHTNESS ISO 20653:2013-02 / MIL-STD-810H 512.5 ISO 20653:2013-02

See protection types on page [50](#).

TOTAL RESISTANCE

Total resistance value measured from terminal to terminal (e.g. without crimp resistance). The specifications are average values.

WIRE

Solid conductor

GENERAL NOTE

The connectors and cable assemblies listed in this catalog are generally designed as connectors without breaking capacity unless otherwise stated. The rated voltage specification given on the respective data sheet must be respected. Suitable precautionary measures must be taken to ensure that people do not come into contact with live conductors during installation and operation. All entries in this catalog were thoroughly reviewed before printing. ODU reserves the right to make changes based on the current status of knowledge without prior notice and without being obliged to provide replacement deliveries or refinements of older designs.

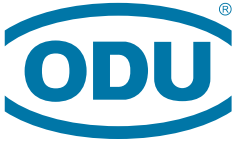

ODU GROUP WORLDWIDE

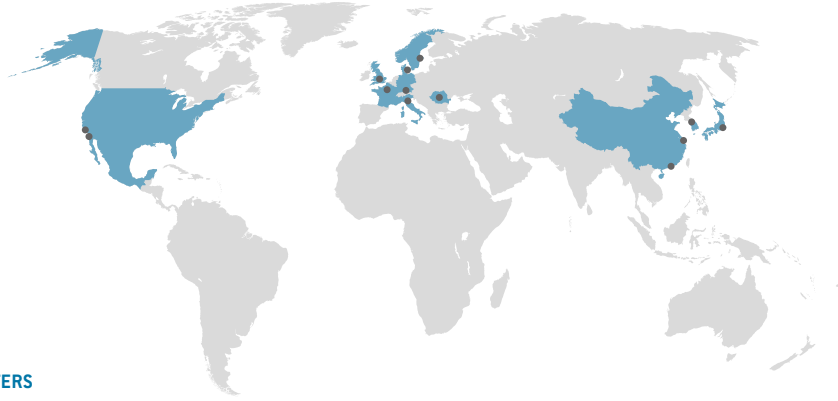

HEADQUARTERS

ODU GmbH & Co. KG

Pregelstraße 11, 84453 Mühldorf a. Inn, Germany

Phone: +49 8631 6156-0, Fax: +49 8631 6156-49, E-mail: sales@odu.de

SALES LOCATIONS

ODU (Shanghai)

International Trading Co., Ltd.

Phone: +86 21 58347828-0

E-mail: sales@odu.com.cn

www.odu.com.cn

ODU (HK) Trading Co., Ltd.

Phone: +852 3963-9588

E-mail: sales@odu.hk

www.odu-connectors.com

ODU Denmark ApS

Phone: +45 2233 5335

E-mail: sales@odu-denmark.dk

www.odu-connectors.com/da

ODU-France SARL

Phone: +33 1 3935-4690

E-mail: sales@odu.fr

www.odu-connectors.com/fr

ODU Italia S.R.L.

Phone: +39 331 2223929

E-mail: sales@odu-italia.it

www.odu-connectors.com/it

ODU Japan K.K.

Phone: +81 3 6441 3210

E-mail: sales@odu.co.jp

www.odu-connectors.com/ja

ODU Korea Inc.

Phone: +82 2 6964 7181

E-mail: sales@odu-korea.kr

www.odu-connectors.com/ko

ODU Romania Manufacturing SRL

Phone: +40 269 704638

E-mail: sales@odu-romania.ro

www.odu-connectors.com/ro

ODU Scandinavia AB

Phone: +46 176 18266

E-mail: sales@odu.se

www.odu-connectors.com/sv

ODU-UK Ltd.

Phone: +44 330 002 0640

E-mail: sales@odu-uk.co.uk

www.odu-connectors.com/uk

ODU-USA Inc.

Phone: +1 805 484-0540

E-mail: sales@odu-usa.com

www.odu-connectors.com/us

Further information and specialized representatives can be found at:

www.odu-connectors.com/contact

PRODUCTION AND LOGISTICS SITES

Germany Otto Dunkel GmbH

China ODU (Shanghai) Connectors Manufacturing Co., Ltd.

Mexico ODU Mexico Manufacturing S. de R.L. de C.V.

Romania ODU Romania Manufacturing SRL

USA ODU North American Logistics Inc.



Simply scan the QR code to download the entire publication.

All dimensions are in mm. Some figures are for illustrative purposes only. Subject to change without notice. Errors and omissions excepted. We reserve the right to change our products and their technical specifications at any time in the interest of technical improvement. This publication supersedes all prior publications. This publication is also available as a PDF file that can be downloaded from www.odu-connectors.com

ODU-USA

ODU AMC® NP

ODUAMC® NP / C / 0423 / EN ©2023